



Limitorque L120 Series Multi-Turn Electric Valve Actuators

For a wide range of process applications



Experience In Motion



Flowserve Limitorque L120 series multi-turn electric actuators have a solid record of making valve control easier in a wide variety of demanding applications.

Proven performers under the most challenging circumstances, Limitorque's L120 actuators are ideal for valves requiring rotary or linear movement.

With nine unit sizes, L120 electric actuators make it easy to meet or exceed your requirements for positive, dependable valve actuation.

Whether used with gate and globe valves, penstocks, or sluice gates, versatile L120 Series actuators operate without modification in any rising or non-rising stem application for linear-action valves. When combined with a Limitorque PT, PTD, or HBC series quarter-turn gear operator, L120 actuators can also be used to control butterfly, ball, and plug valves, as well as damper drives, flop gates, or any other device which requires rotary movement.

Rugged, reliable, and versatile, L120 actuators are proven performers in challenging applications. Thousands of L120 actuators are at work in some of the world's most demanding conditions, where nothing less than day-after-day dependable operation is acceptable.

L120 actuators are specified for use in petrochemical, power generation, and water and waste treatment applications where failure of a single actuator can be extremely costly...even catastrophic.

Solid design and durable construction qualify the L120 actuator for applications involving harsh environmental conditions. A successful record with challenging requirements and compatibility with advanced process control systems make L120 actuators the best combination of proven and leading-edge technologies. Backed by comprehensive technical support services, product documentation, and spare parts availability, the L120 series is an easy choice for flexible, dependable valve control.

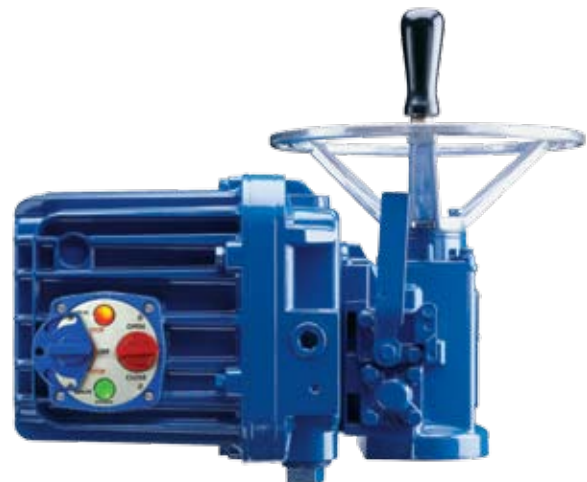

Low-maintenance requirements make the L120 Series ideally suited for water and waste treatment applications.

L120 actuators meet rigid safety requirements and are available in weatherproof, explosionproof, and submersible configurations.



The L120 makes valve control easier for some of the world's most demanding customers.

Petrochemical installations such as refineries, pipelines, terminals, tank farms, cokers, and off-shore platforms rely on the L120's safety, endurance, and operational efficiencies. The L120 has network compatibility, explosionproof certification, and resistance to lightning, EMI, and fire.

Power generation plants value the L120's availability, controls versatility, and reliable performance. The L120's rugged design and construction quality stands up to vibration, high-pressure steam, and extreme temperatures.

Water and waste treatment facilities benefit from the L120's low-maintenance requirements and modulating control capabilities. Actuators meet AWWA standards and easily fit the industry trend toward modern controls networks. The wide range of options in the L120 Series allows specification needs to be met cost-effectively.

Designed to provide positive, dependable actuation.

The time-tested design and solid construction of the L120 series allow these actuators to handle up to 60,000 ft-lb (81,600 N m) of torque, and up to 500,000 ft-lb (225,000 kg) of thrust. Durable torque overload protection is provided in both directions of valve travel. Rugged enclosures are available in weatherproof, submersible, and explosionproof configurations.

L120 actuators can also be coupled to gearboxes such as Limitorque's B320, MT, PT, PTD, or HBC operators for motorized operation of valves requiring quarter-turn operation or multi-turn applications for increased torque and/or thrust requirements.

All L120 actuators are factory-lubricated and weather-proofed for service in temperature ranges from -50°C to 65°C (-56°F to 150°F). Submersible, explosionproof, and extremely cold temperature versions of all L120 models are available for appropriate applications. Refer to pages 8 and 9 for L120 specifications.

L120 series multi-turn electric valve actuators

L120-10 through -40 series

These models utilize die-cast aluminum with an option for ductile iron construction to withstand the most rigorous applications.

All metallic gearing is lubricated. Anti-friction bearings are used throughout.

Reliable motor includes class F insulation and thermal protection; it is specially designed for valve actuation.

A four-position, 16-contact geared limit switch is standard on all models. The gear train is fully enclosed.

Manual declutch lever mechanically disconnects the motor from the handwheel through the clutch assembly. Return to motor operation is automatic in all actuators when the motor is energized.

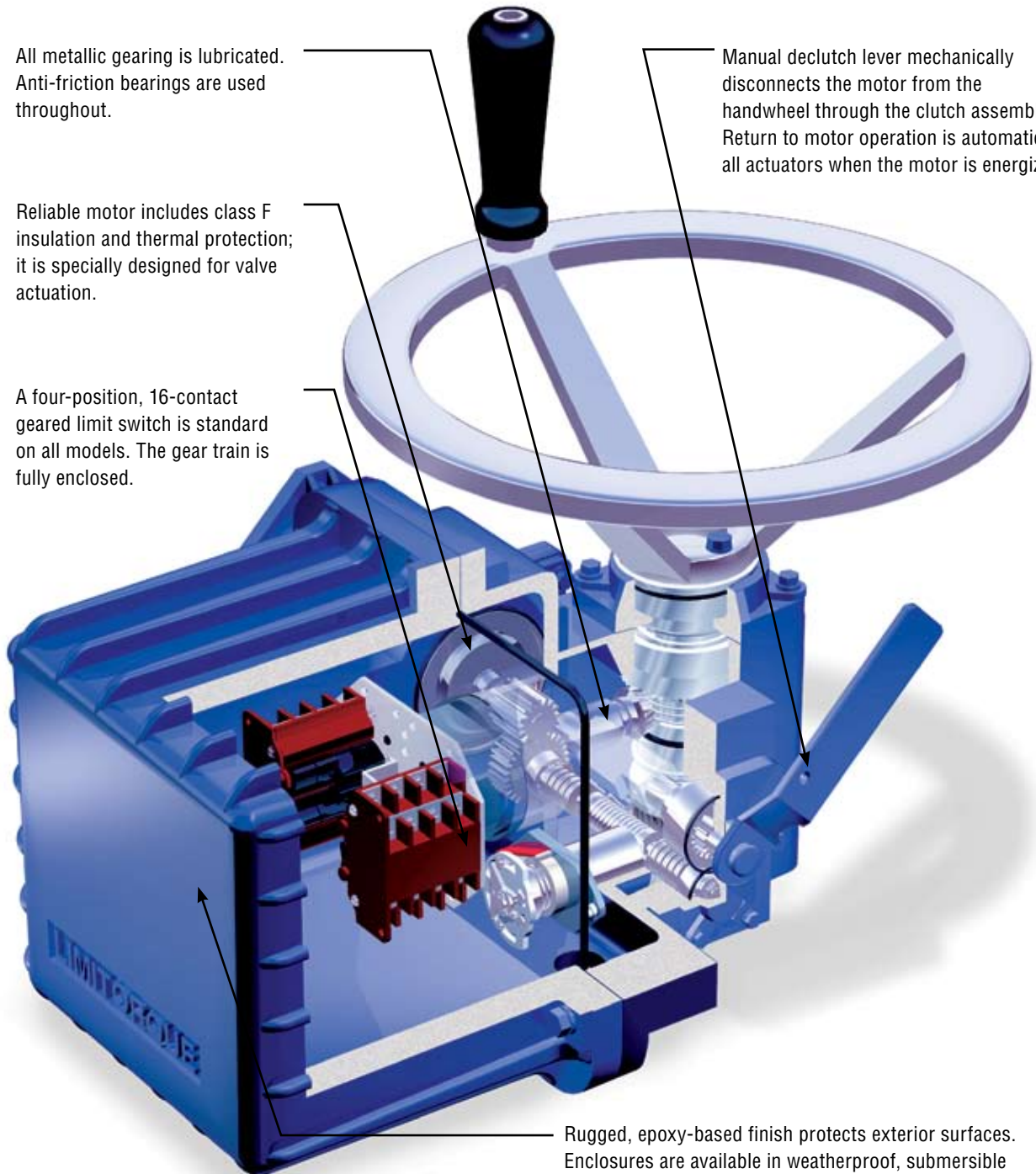

Rugged, epoxy-based finish protects exterior surfaces. Enclosures are available in weatherproof, submersible and explosionproof construction. Gaskets and seals throughout prevent exposure to the elements.

L120-85 series

This model and larger actuators feature cast iron construction. Optional ductile iron construction is also available.



L120-190 series

This versatile midrange member of the L120 family delivers more than seven times the thrust of the smallest actuators in the line.



L120 actuators offer easy control of all types of valves.

Direct mounting The L120 series can be directly coupled with valves for torque-only applications. For thrust applications, a separate thrust base is used for the L120-10 through -85.

L120/B320 AND L120/MT Rising stem valves may be operated by an L120 coupled to a B320 or MT bevel gear operator. Thrusts up to 325,000 lb/147,420 N and torque up to 8,000 ft-lb/10,850 N m can be accommodated.

L120/PT/PTD/HBC The L120 series may be coupled to a worm gear reducer for operation of quarter-turn valves such as butterfly, balls, plugs, and dampers.

Valve mounting options

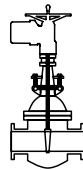

L120 mounted to wedge gate

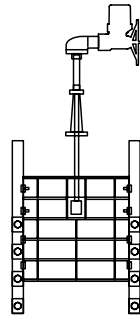

L120/B320 mounted to sluice gate

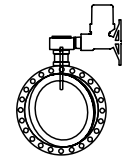

L120/PT mounted to butterfly valve

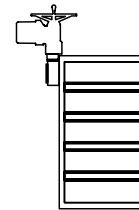

L120/PT mounted to damper

Mounting bases

Thrust actuator drive bases

Type A1 (drive 2) – Alloy bronze (torque and thrust)

Torque-only actuator bases

Type B4 (drive 1) – Standard steel bushing

Type BL (drive 3) – Splined steel bushing for rising or rotating stem valves

Mounting bases (L120-10 through -85)

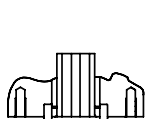

Type B4 (drive 1)

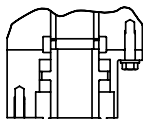

Type A1 (drive 2)

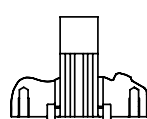

Type BL (drive 3)
L120-10 through -40

Combinations for torque reduction applications

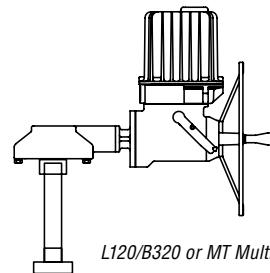

L120/B320 or MT Multi-turn

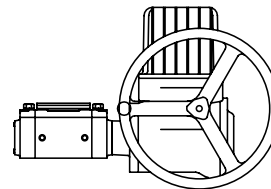

L120/HBC, PT, or PTD Quarter-turn

Compatible control options include switches, illuminated indicators, integral packages, and digital networks linked direct-to-host.

Even though it has been at work for years, the L120 is at home in the most modern process control environments. It is compatible with a wide range of control options — from stand-alone actuators with local controls to open-standards-based, direct-to-host DDC networks with up to 250 actuators.

Human interfaces

Control stations are available with a variety of illuminated indicator and selector switch options. The control stations offer two lights and padlockable selector switches as standard for use with electronic controllers. Switch stations can be supplied in the compartment cover (standard) or for remote mounting.

Control compartments

Options for compartment sizes fit different control requirements. The smallest size is supplied to suit any application, unless another size is specified.

- **L120-10 through -190** Three sizes are available: standard – for NCU and BIC, plus some BIC configurations; minimum integral compartment – for clamshell, electronic integral controls, and L120-10 through -40 single-phase BIC; and maximum compartment – for some Modutronic controllers and customized options which do not fit smaller compartment sizes.
- **L120-420 and larger** Two sizes apply: a standard compartment for non-integral controls and an integral compartment for integral controls.

Control stations

Typical control stations offer basic control functions.

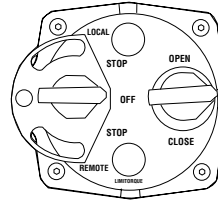

Advanced control stations support electronic control functions.

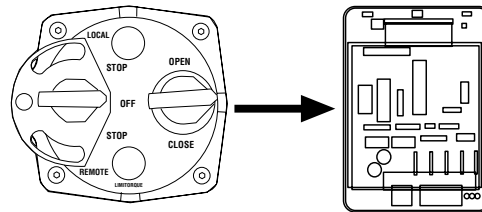

L120 control compartments

Standard compartment

- L120-10 through -190 for NCU and BIC controls
- L120-420 and larger for non-integral controls

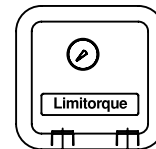

Minimum integral compartment

- L120-10 through -40 for single-phase BIC, and clamshell controls
- L120-85 through -190 for clamshell controls

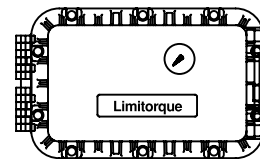

Maximum integral compartment

- L120-10 through -190 for some modutronic packages and other customized options
- L120-420 and larger for integral controls

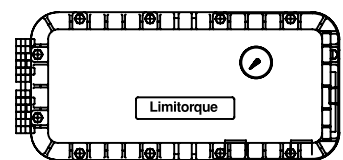

Integral control packages expand L120 functionality.

Standard packages are provided on printed circuit boards to reduce the need for hard wiring. Local control stations offer a choice of indicator light and selector switch options. Control functions vary according to application requirements.

Integral package options:

- No Controls Unit (NCU) control of open/close applications can be linked to a motor control center or PLC to keep equipment costs to a minimum.
- Basic Integral Controls (BIC) include integrated reversing contactor, transformer, fuses, and interlocks.
- Integral Reversing Controls (IRC) include BIC functionality plus plug-in interconnect board and increased options. IRC packages are mounted on hinged clamshell bracket for easy accessibility.
- Modutronic Controls (BIC/MOD 20) offer a choice of integral packages for positioning or process control functions in response to analog signals. Use with BIC and IRC packages.
- Electronic controls offer state-of-the-art actuator control with advanced diagnostics and configurability. Available features include open/close, modulating, analog I/O, digital I/O, and networked protocols. Available protocols include DDC, PROFIBUS, and FOUNDATION Fieldbus.

Advanced features simplify control characteristics

No-controls unit

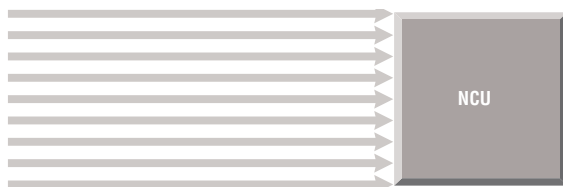

Basic integral control (BIC)

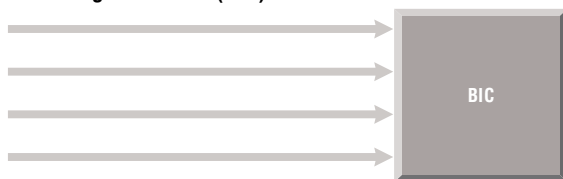

Electronic controller with distributed digital control



L120/DDC direct-to-host networks support up to 250 field units

Host Controller

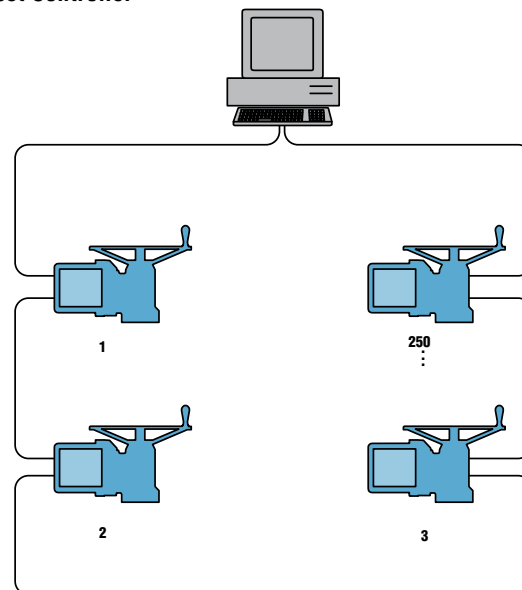

L120 Specifications

Gear housing

- Cast aluminum, L120-10 through -40; cast iron, L120-85 through -2000.
- Lubrication — Grade 0 or Grade 00.
- Gear reduction — Double reduction type.
 - › Worm gear (alloy bronze) and spur gear (heat-treated steel), L120-10 through 85.
 - › Worm gear (alloy bronze) and spur gear (heat-treated steel), and worm (alloy steel) and helical gearing (heat-treated steel), L120-190 through -2000.

Electrical compartment covers

- Cast aluminum, O-ring sealed.
 - › Hardware is nickel-plated carbon steel, L120-10 through -85, and L120-190 through -2000. Stainless steel optional for non-XP.

Motor

- Available as four-pole, 1800 RPM (60Hz) or 1500 RPM (50Hz); two-pole, 3600 RPM (60Hz) or 3000 RPM (50Hz); eight-pole, 900 RPM (60Hz) or 750 RPM (50Hz).
- Squirrel-cage induction for three-phase and capacitor start-induction run for single-phase.
- Power supply — three-phase motors, suitable for 3/60/230, 3/60/460, 3/60/575, 3/50/380, or 3/50/415.
- Nominal duty is 15 minutes.
- Dynamic torque is nominal 20% of start torque.
- Class F insulation.
- Two Class B thermal contacts embedded within motor windings provide thermal protection.

Limit switch

- Gear driven, cam operated, snap acting.
- Four rotor/16 SPST contact switches (four contacts per rotor — 2 N/O and 2 N/C). Rotors may be set to open or close at any valve position.
- Contact rating is 600 volts per ICS-125.6. Current rated 6 amps resistive and 60 amps inrush at 120 VAC.
- Max drive sleeve turns (four-gear) rated 630 for L120-10; 740 for L120-20; 640 for L120-40; 900 for L120-85; 3110 for L120-190; 3300 for L120-420; 2850 for L120-800; 1210 for L120-2000.

Torque switch

- L120-10 through -85: Heavy-duty inlaid silver contacts, 600 volts, and one SPST contact each for open/closed direction dedicated to actuator torque protection.
- L120-190 through -2000: 600 volts per ICS-125.6, 6 amps resistive and 60 amps inrush at 120 VAC. One SPST contact each for open/closed direction dedicated to actuator torque protection.

Reversing contactor

- Available at 12-, 25- or 50-amp ratings, selected according to motor ratings.

Enclosure

- WP actuators suitable for NEMA 4.
- XP actuators suitable for
 - › FM Class I, Groups B, C, D, Divisions 1 and 2; Class II, Groups E, F, G, Divisions 1 and 2.
 - › CSA Class I, Groups C, D, Divisions 1 and 2; Class II, Groups E, F, G, Divisions 1 and 2

NOTE: XP actuators also carry NEMA 3 and 4 ratings.

Output drive B4

- Steel torque bushing, no internal machining. Torque bushing is flush with mounting base, not extended.

Handwheel/declutch

- Fabricated steel, or ductile iron for side-mounted; cast aluminum for L120-10 top-mounted only. Handwheels are connected directly to drive sleeve (L120-10, -20 and -40). L120-85 operates through the worm set. Declutch lever is padlockable in motor position.

Mounting base

- Supplied to MSS (English taps) standard. Optional ISO bases available.

Paint

- Valspar epoxy/polyurethane and E-coating (electro-deposition) for L120-10 through -40; Valspar epoxy/polyurethane for L120-85 through -2000. Both coatings are suitable for 500-hour salt spray.

Temperature rating

- Standard operating temperature range is from -20°F to 150°F. Optional extended ranges available.
- FM explosionproof rating -20°F to 140°F (-20°C to 60°C) Unit nameplate

Actuator nameplate

- Flowserve Limitorque name, point of manufacture, actuator type and size, order number, serial number, space for customer tag information. Nameplate located on back of actuator opposite the limit switch compartment.

Motor nameplate

- ID number, start torque, run torque, enclosure type, RPM, volts, full load amps, locked rotor amps, insulation class, duty, space heater size, horsepower, service factor, phase, cycles, motor code, ambient temperature, connection diagram.

XP nameplate

- L120-10 through -85:
 - › Nameplated as Class I, Groups B, C, D, Divisions 1 and 2; Class II, Groups E, F, G, Divisions 1 and 2 with FM label. Class I, Groups C, D, Divisions 1 and 2; Class II, Groups E, F, G, Divisions 1 and 2 with CSA label.
 - › FM and CSA labels available for NCU and standard controls packages.
- L120-190 through -2000:
 - › Nameplated as Class I, Groups C and D, Divisions 1 and 2, and Class II, Groups E, F and G, Divisions 1 and 2, FM or CSA label.

Options

- **Flip-flop indication** Local position indicator shows open-intermediate-closed positions and is driven by gear limit switch rotors. Window in compartment cover shows indicator.
- **Local continuous position indication** Local position indicator shows continuous valve position in percentage open via dial, and is driven by dedicated gear set selected per application. Window in compartment cover shows indicator.
- **Local/remote indication** Includes local continuous position indicator with a 1000-ohm potentiometer. Potentiometers transmit valve position to remote location.
- **R/I converter** Sends remote valve position indication signal via 4-20 mA signal. Internally-powered.
- **Relay boards** Provide isolated relays (2) or non-isolated relays (3) for interlocking with field equipment. Relay contacts rated at 250 VAC/6.5 A or 30 VDC/5 A.
- **Side-mounted handwheel (L120-10 through -40)** Bevel gear attachment may be added to reduce effort required to operate handwheel, requiring more turns.
- **Handwheel spur (L120-190 through -2000)** May be added to reduce effort required to operate handwheel, requiring more turns.
- **Five-gear limit switch** Used when the number of drive sleeve turns exceeds capacity of four-gear limit switch. Provides 10 times the number of turns as four-gear switch.
- **Double-pole torque switch** Provides an additional SPDT contact in each direction that actuates when set torque is exceeded. Used as indication of over-torque condition.
- **Ductile iron housing (L120-10 through -40)** Ductile iron for load-carrying components.
- **Spring compensation (L120S) (L120-190 through -2000)** SB-type spring-compensated stem nut used on high-speed, or high-temperature, torque-seated applications.
- **Position feedback for DDC** Communicates valve position to remote location via DDC network. Includes local position indication, 1000-ohm potentiometer, and DDC analog channel. Used with DDC base actuator.

- **External analog feedback for DDC** Allows external analog signals to be connected to DDC field unit, converted to digital signals, and transmitted over DDC network. Four signals may be accommodated. Includes DDC analog channel. Used with DDC base actuator.
- **Positioning control for DDC** Permits positioning of valves over DDC network. Positioning commands valve to any point of travel, in 1% increments. Includes local position indication, 1000-ohm potentiometer, and DDC analog channel. Used with DDC base actuator.
- **Two-speed operation for DDC** Allows the actuator to be pulsed on and off, achieving slower operating speed for all or part of valve stroke. Default pulse rate is 2 seconds on, 10 seconds off, adjustable from 50 ms to 12.75 seconds in 50-ms increments. Configured via RS-232 link and dedicated software.

Testing summary

Weatherproof enclosures meet NEMA 4, NEMA 4X, and IP67. Submersible actuators are suitable for NEMA 6 and IP68. Explosionproof enclosures fully conform to and are certified to be compliant to the following:

- Factory Mutual (FM) — Class I, Divisions 1 and 2, Groups B, C and D and Class II, Divisions 1 and 2, Groups E, F, G; Temp Code T3C.
- Canadian Standards Association (CSA) — Class I, Division 1, Groups C and D and Class II, Division 1, Groups E, F and G; Temp Code T3C

Limitorque's factories are certified to ISO 9001 standards and maintain the highest quality of performance throughout the manufacturing processes.

L120 actuators meet the following seismic and vibration criteria: NTS Labs, Acton, MA, Test Report #31437-94M dated 3/28/94 to the following:

- Sine survey; 5 to 200 Hz @ 0.75 g.
- Sine cycling; 5 to 200 Hz to 5 Hz @ 0.75 g.
- Sine cycling; 2 to 35 to 2 Hz @ 1.0 g; 10 cycles.
- Sine dwells; 2 to 35 to 2 Hz @ 1/3-octave intervals, 5.0 g @ 15-second dwells each frequency.

NOTE: Standards are applicable to most actuators.

L120 Series Performance

(3-phase-50 Hz/380, 400, and 415 V — 60 Hz/230, 460, and 575 V)

Actuator	Maximum Torque Capacity		Maximum Thrust Capacity		Output Speed Range (RPM)	
	ft-lb	N m	lb	kg	60 Hz	50 Hz
L120-10	100	136	10000	4500	12-250	10-210
L120-20	200	272	20000	9000	12-250	10-210
L120-40	400	544	30000	13500	24-250	20-210
L120-85	850	1156	45000	20250	24-192	20-160
L120-190	1900	2584	75000	33750	24-196	20-160
L120-420	4200	5712	140000	63000	19-196	16-165
L120-800	8000	10880	250000	112500	12-168	10-140
L120-2000	20000	27200	500000	225000	12-60	10-50

Maximum stem acceptance

Actuator	Threaded Stem Nut		Bore		Keyway		Handwheel Gear Ratio	
	in.	mm	in.	mm	in.	mm	STD	Optional
L120-10	1.25	32	1	25	¼ x ⅜	8 x 6	1:1	4.2:1
L120-20	2.25	57	1.875	47	½ x ⅝	14 x 9	1:1	5.7:1
L120-40	2.625	66	2.125	52	½ x ⅝	16 x 10	1:1	12:01
L120-85	3.25	76	2.75	70	⅝ x ⅞	20 x 12	18:1–71:1 (see Note 1)	
L120-190	3.5	89	2.875	73	¾ x 1¼	20 x 12	22:1	88:1
L120-420	5	127	4.25	108	1 x ¾	28 x 16	28:1	170:1
L120-800	5	127	7	178	1 x ¾	32 x 18	N/A	24:168
L120-2000	6.25	159	8	203	1-¼ x ⅞	40 x 22	270:1	772:1

L120 weights (approx.)

Actuator	Actuator with STD Comp.		Add for Integral Comp.		Add for Max. Comp.		Add for Thrust Base		Add for Side-Mount Handwheel	
	lb	kg	lb	kg	lb	kg	lb	kg	lb	kg
L120-10	90	41	20	9	32	14	7	3	3	1
L120-20	115	52	20	9	32	14	13	6	8	4
L120-40	160	72	20	9	32	14	22	10	16	7
L120-85	285	129	20	9	32	14	67	30	(Note 2)	
L120-190	600	272	85	39	(Note 2)		(Note 2)		(Note 2)	
L120-420	1195	541	215	98	(Note 2)		(Note 2)		(Note 2)	
L120-800	1415	641	215	98	(Note 2)		430	195	(Note 2)	
L120-2000	2550	1155	215	98	(Note 2)		826	375	(Note 2)	

Note 1: Same as overall ratio.

Note 2: Consult factory for weight.

Note 3: Performance ratings and dimensions are also available for the L120-6000. Please consult factory.

Mounting Base and Drive Sleeves

	Previous Designation	Description
Type B4	Drive 1	Bore and key bushing for torque-only applications
Type A1	Drive 2	Threaded for thrust applications
Type BL	Drive 3	Splined steel bushing for rising rotating stem valves

L120-10, -20 and -40

Drive sleeve	L120-10		L120-20		L120-40	
	in.	mm	in.	mm	in.	mm
Type B4 bore	1.00	24.5	1.88	47.8	2.13	54.1
Type B4 key	1/4 x 3/32		1/2 x 3/16		1/2 x 3/16	
Type B4 stem nut	2.87	73	3.12	79	3.37	86
Type A1 threaded stem	1.25	32.8	2.25	57.2	2.63	66.8
Type A1 stem length	2.83	60	3.25	83	3.86	98
Type BL splined	6 and 38 splines		6 and 38 splines		6 splines	
Type BL spline length	4.5	114	4.5	114	4.5	114
Mounting base	MSS	ISO	MSS	ISO	MSS	ISO
Pilot diameter	2.312	70	3.750	100	3.750	100
Mounting holes (Note 1)	(4)3/8-16x.88	(4)M10x1.5x22.4	(4)3/8-11x1.25	(4)M16x2x32	(4)3/8-11x1.25	(4)M16x2x32
Between centers	4.016	102	5.5	140	5.5	140
Mounting base diameter	4.92	125	7.00	178	7.00	178

L120-85, -190 and -420

Drive sleeve	L120-85		L120-190		L120-420	
	in.	mm	in.	mm	in.	mm
Type B4 bore	2.75	69.9	2.88	73.2	4.25	108
Type B4 key	5/8 x 7/32		3/4 x 1/4		1 x 3/8	
Type A1 threaded stem	3.0	76	3.5	89	5	127
Type A1 stem length	7	177.8	8.25	209.6	9.38	238.3
Mounting base	MSS	ISO	MSS	ISO	MSS	ISO
Pilot diameter	5	130	7	230	8.5	215.9
Mounting holes (Note 1)	(4)3/4-10x1.0	(4)M20x2.5x26(s)	(8)3/4-10x1.13(s)	(8)M20x2.5x32	(8)7/8-9x1.75	(8)M30x3.5x1.75
Between centers	6.5	165.1	11.75	298	14	355.6
Mounting base diameter	8.25	209.6	13.5	343	16	406.4

Note 1: Mounting holes straddle centerline.

Note 2: L120-85, -190 and -420 are suitable for both torque and thrust applications. L120-optional. L120-2000 is suitable for torque as standard; thrust units are optional.

L120-800 and -2000

Drive sleeve	L120-800		L120-2000	
	in.	mm	in.	mm
Type B4 bore	4.5	108	6.25	159
Type B4 key	1 x 1/2	N/A	1.24 x .438	N/A
Type B4 stem nut	11	279.4	12	304.8
Type A1 threaded stem	5	127	6.25	159
Type A1 stem length	2	50.8	3.125	79.4
Type A1 base to drive sl.	15.5	393.7	18.6	472.4
Mounting base	MSS	ISO	MSS	ISO
Pilot diameter	9	300	13	330
Mounting holes (Note 1)	(8)1.25-7x2.00	(8)M36x4x64	(12)15-6x3 N/A	
Between centers	16	406	18	457.2
Mounting base diameter	18.8	477.5	21	533.4

Note 1: Mounting holes straddle centerline.

Note 2: L120-85, -190, -420, and -800 are suitable for both torque and thrust applications. L120-2000 is suitable for torque as standard; thrust base is optional.

Standard Compartment, L120-10 Through -40

Top view

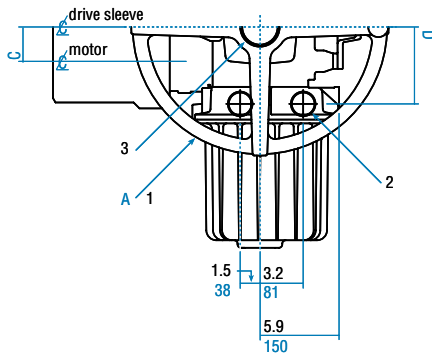

Side view

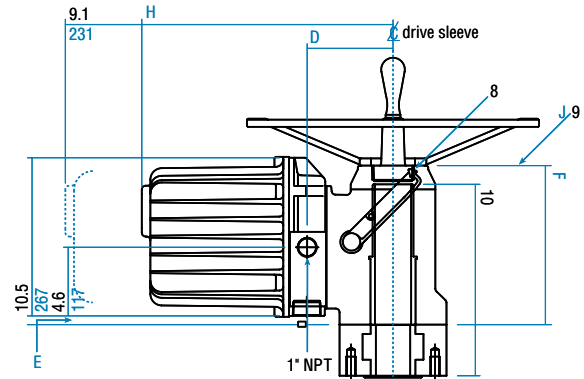

Front view

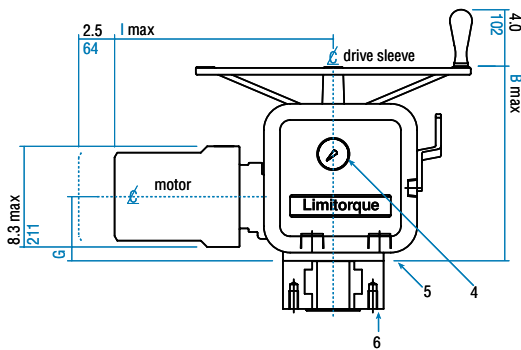

Dimensions in inches

	A	B	C	D	E	F	G	H	I	J
L120-10	12	12.1	1.6	4.7	1.10	8.5	4.0	15.4	14.2	1.25
L120-20	18	13.6	2.6	5.7	0.51	10.6	4.4	16.4	16.0	2.5
L120-40	24	16.1	2.5	6.2	1.21	12.0	5.2	17.0	18.9	3

Dimensions in millimeters

	A	B	C	D	E	F	G	H	I	J
L120-10	305	307	41	119	28	216	102	391	361	32
L120-20	457	345	66	145	13	269	112	417	406	64
L120-40	607	409	64	158	30	305	132	432	480	76

Item 1: A dimension is the standard diameter handwheel.

Item 2: 1-½ NPT (2) places farside.

Item 3: J NPT (type A1 (drive 2) only).

Item 4: Position indicator.

Item 5: Mounting base location for types B4 (drive 1) and BL (drive 3).

Item 6: Mounting base location for type A1 (drive 2).

Item 8: Declutch lever is padlockable in motor operation.

Item 9: Reference location of J NPT for stem cover.

Item 10: Maximum rising stem without stem cover.

NOTE: Actuator turns clockwise to close (left-hand thread). If other rotation is required, it must be specifically requested.

Minimum Integral Compartment, L120-10 Through -40

Top view

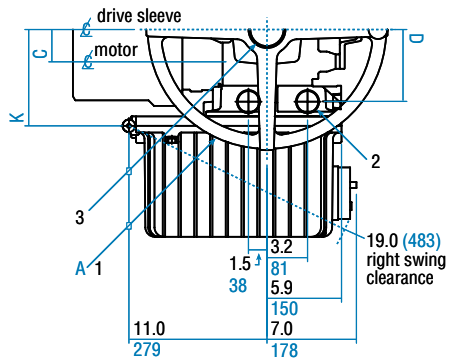

Side view

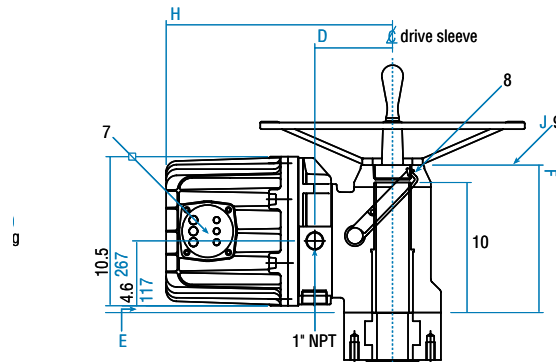

Front view

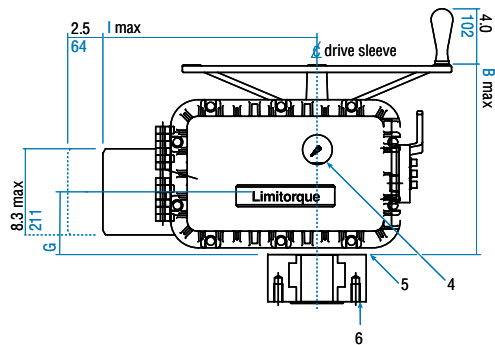

Dimensions in inches

	A	B	C	D	E	F	G	H	I	J	K
L120-10	12	12.1	1.6	4.7	1.10	8.5	4.0	15.4	14.2	1.25	6.6
L120-20	18	13.6	2.6	5.7	0.51	10.6	4.4	16.4	16.0	2.5	7.6
L120-40	24	16.1	2.5	6.2	1.21	12.0	5.2	17.0	18.9	3	8.1

Dimensions in millimeters

	A	B	C	D	E	F	G	H	I	J	K
L120-10	305	307	41	119	28	216	102	391	361	32	168
L120-20	457	345	66	145	13	269	112	417	406	64	193
L120-40	607	409	64	158	30	305	132	432	480	76	206

Item 1: A dimension is the standard diameter handwheel.

Item 2: 1-½ NPT (2) places farside.

Item 3: J NPT (type A1 (drive 2) only).

Item 4: Position indicator.

Item 5: Mounting base location for types B4 (drive 1) and BL (drive 3).

Item 6: Mounting base location for type A1 (drive 2).

Item 7: Selector switch control elements. See wiring diagram for quantity and function.

Item 8: Declutch lever is padlockable in motor operation.

Item 9: Reference location of J NPT for stem cover.

Item 10: Maximum rising stem without stem cover.

NOTE: Actuator turns clockwise to close (left-hand thread). If other rotation is required, it must be specifically requested.

Maximum Integral Compartment, L120-10 Through -40

Top view

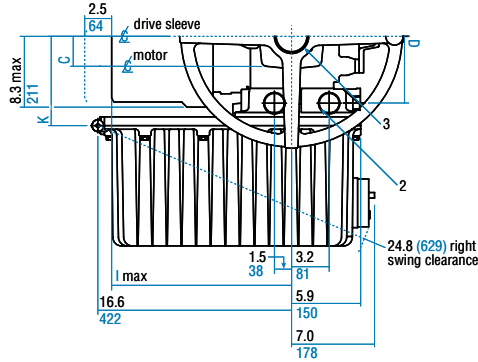

Side view

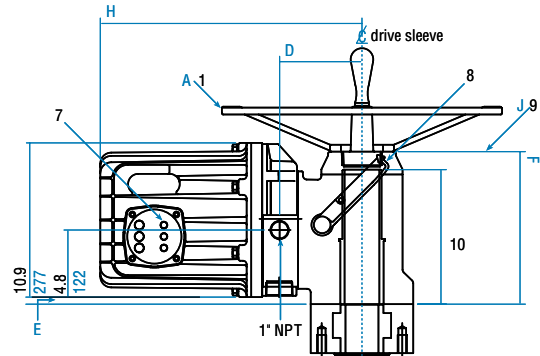

Front view

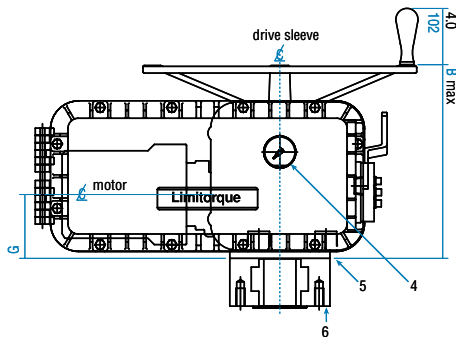

Dimensions in inches

	A	B	C	D	E	F	G	H	I	J	K
L120-10	12	12.1	1.6	4.7	0.0	8.5	4.0	16.8	14.2	1.25	5.8
L120-20	18	13.6	2.6	5.7	0.35	10.6	4.4	17.8	16.0	2.5	6.8
L120-40	24	14.0	2.5	6.2	1.01	12.0	5.2	18.4	18.9	3	7.4

Dimensions in millimeters

	A	B	C	D	E	F	G	H	I	J	K
L120-10	305	307	41	119	0	216	102	427	361	32	147
L120-20	457	345	66	145	9	269	112	452	406	64	173
L120-40	610	356	64	158	26	305	132	467	480	76	188

Item 1: A dimension is the standard diameter handwheel.

Item 2: 1-½ NPT (2) places farside.

Item 3: J NPT (type A1 (drive 2) only).

Item 4: Position indicator.

Item 5: Mounting base location for types B4 (drive 1) and BL (drive 3).

Item 6: Mounting base location for type A1 (drive 2).

Item 7: Selector switch control elements. See wiring diagram for quantity and function.

Item 8: Declutch lever is padlockable in motor operation.

Item 9: Reference location of J NPT for stem cover.

Item 10: Maximum rising stem without stem cover.

NOTE: Actuator turns clockwise to close (left-hand thread). If other rotation is required, it must be specifically requested.

Minimum Integral Compartment, L120-85 (Shown) and -190, MSS (Note 3) and ISO bases (Note 4)

Top view

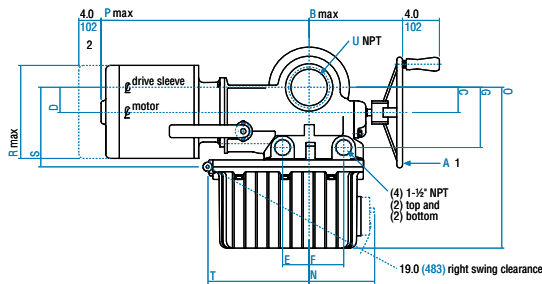

Side view

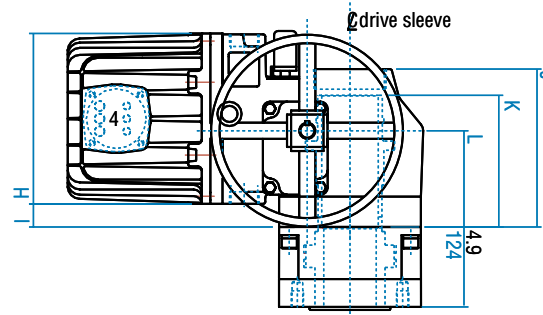

Front view

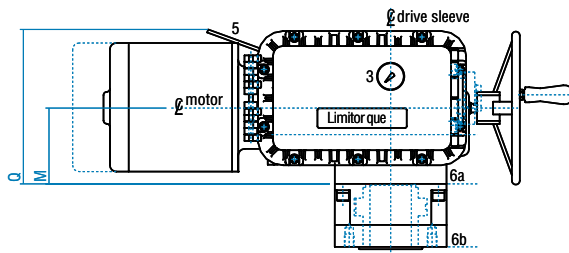

Dimensions in inches

	A	B	C	D	E	F	G	H	I	J	K	L	M	N	O	P	Q	R	S	T	U
L120-85	12	10.1	2.7	2.7	2.8	3.8	6.5	10.5	1.4	9.8	8.1	5.9	5.9	7.0	17.4	25.7	12.1	10.5	8.6	11.0	4
L120-190	18	15.5	4.4	4.4	5.1	5.5	8.2	10.8	0.8	13.3	11.1	8.3	6.6	5.5	18.1	32.2	14.7	12.5	9.6	8.0	5

Dimensions in millimeters

	A	B	C	D	E	F	G	H	I	J	K	L	M	N	O	P	Q	R	S	T	U
L120-85	305	257	69	69	71	97	165	267	36	249	206	150	150	179	442	653	307	267	218	279	102
L120-190	457	394	112	112	130	140	208	274	20	338	282	209.6	168	140	460	818	373	318	244	203	127

Item 1: A dimension is the standard diameter handwheel.

Item 2: Space for motor removal.

Item 3: Position indicator.

Item 4: Selector switch control elements. See wiring diagram for quantity and function.

Item 5: Declutch lever is padlockable in motor operation.

Item 6a (L120-85 only): Mounting location for base type BL (drive 1).

Item 6b (L120-85 only): Mounting location for base type A1 (drive 2).

NOTE 1: Actuator turns clockwise to close (left-hand thread). If other rotation is required, it must be specifically requested.

NOTE 2: Larger actuators are also available (L120-420, -800, and -2000). Above drawings may apply with some variations.

NOTE 3: Provided with NPT taps and imperial dimensions per MSS standard.

NOTE 4: Provided with metric taps and dimensions per ISO standard.



**Flowserve Corporation
Flow Control**

United States

Flowserve Limitorque
5114 Woodall Road,
P.O. Box 11318
Lynchburg, VA 24506-1318
Phone: 434-528-4400
Facsimile: 434-845-9736

England

Flowserve Limitorque
Euro House
Abex Road
Newbury
Berkshire, RG14 5EY
United Kingdom
Phone: 44-1-635-46999
Facsimile: 44-1-635-36034

Japan

Limitorque – Nippon Gear Co., Ltd.
Asahi-Seimei Bldg. 4th Floor
1-11-11 Kita-Saiwai, Nishi-Ku
Yokohama-Shi, (220-0004)
Japan
Phone: 81-45-326-2065
Facsimile: 81-45-320-5962

Canada

Flowserve Limitorque
120 Vinyl Court
Woodbridge, Ontario L4L 4A3
Canada
Phone 905-856-4565
Fax 905-856-7905

Singapore

Limitorque Asia, Pte., Ltd.
12, Tuas Avenue 20
Singapore 638824
Phone: 65-6868-4628
Facsimile: 65-6862-4940

**To find your local Flowserve representative,
visit www.flowserve.com or call USA 1 800 225 6989**

FCD LMENBR1200-02 02/07 Printed in USA.

Flowserve Corporation has established industry leadership in the design and manufacture of its products. When properly selected, this Flowserve product is designed to perform its intended function safely during its useful life. However, the purchaser or user of Flowserve products should be aware that Flowserve products might be used in numerous applications under a wide variety of industrial service conditions. Although Flowserve can (and often does) provide general guidelines, it cannot provide specific data and warnings for all possible applications. The purchaser/user must therefore assume the ultimate responsibility for the proper sizing and selection, installation, operation, and maintenance of Flowserve products. The purchaser/user should read and understand the Installation Operation Maintenance (IOM) instructions included with the product, and train its employees and contractors in the safe use of Flowserve products in connection with the specific application.

While the information and specifications contained in this literature are believed to be accurate, they are supplied for informative purposes only and should not be considered certified or as a guarantee of satisfactory results by reliance thereon. Nothing contained herein is to be construed as a warranty or guarantee, express or implied, regarding any matter with respect to this product. Because Flowserve is continually improving and upgrading its product design, the specifications, dimensions and information contained herein are subject to change without notice. Should any question arise concerning these provisions, the purchaser/user should contact Flowserve Corporation at any one of its worldwide operations or offices.

© 2007 Flowserve Corporation, Irving, Texas, USA. Flowserve is a registered trademark of Flowserve Corporation.